

ABS Engineering (Hong Kong) Limited  
Serving Hong Kong and the World Since 2001

## Introducing A New Generation of Sewer Cleaning, Odor/Septicities Control Technology

Unit 19, 6/F. Block A, 31-41 Shan Mei Street,  
Fo Tan, Shatin, Hong Kong.

Tel +852-21714882; Fax: +852-2385-7457

Web: [www.abs-hk.net](http://www.abs-hk.net), Email: [gkw@abs-hk.net](mailto:gkw@abs-hk.net)



100% Nature Microbial Enhancer

Proudly Hong Kong

### H2O2 Enhancer



Preserve H2O2  
Potency up to 72 hrs



ABS Engineering (Hong Kong) Limited

Unit 19, 6/F, Wah Lok Building,

31-41, Shan Mei St. Fo Tan, Shatin, HK.

Tel: +852-21714882; Fax: +852-2385-7457

24 hrs Answering Service: + 852-9345-4842

Branch Office: Taipei, Taiwan; Shenzhen, PRC

Intl Distributor: USA/Canada, India, Australia,

## ABS-182 is the Most Powerful and Economical to Revitalize Inland Waterway, Natural/Artificial Lakes in 3 Dimensions

---



ABS 182Plus Liquid Phase Microbial Enhance is a blended of proprietary formulation of over 25 active ingredients are derived from three distinctive biological elixir groups:

- Bio Catalysts
- Secondary Metabolites (Biological Extracts)
- Amino Acids, Co-Enzymes, Trace Minerals
- Polysaccharides, Macronutrients, Micronutrients
- Trace Minerals

To accelerate the bioactivities by nurture the beneficial facultative bacteria and suppress sulfide forming bacteria to increase the treatabilities of any wastewater treatment system



All products are made under the GMP guild line and criteria. Currently we are seeking ISO accreditation before 2010. All ABS Treatment Formulations does not contain Hormone, Bacteria, Steroid, Antibiotic, Humic Acid to further threatening aquatic lives from fish, vegetation, soil, microbes, beneficial and non-beneficial bacteria population.

All ABS Products are USEPA 40 CFR152.25 (a) EPA - 63838-1 Equivalent: 21CFR 178.1010 Equivalent: FAO/WHO Expert Committee C.O.E. No.10; FEMA No.2799, JECFA No.99 Equivalent. Products Are Manufactured Under USA GMP Processing Criteria

# ABS-Hydrogen Peroxide Alleviating Medium

Serving Hong Kong and the world market since 2001



Cat: ABS-181

**ABS-Oxygen Alleviating Medium:** is a liquefied Oxygen Alleviating Agent added to 50% Hydrogen Peroxide to stop the buildup of Toxic Gases in Sewer Line to Protect Life, prevent Sewer Line Constriction, anti-corrosion, expand its lifespan and reduce the organic loading to save government exponential cost in Sewer Line Cleanup and wastewater treatment costs, whilst providing the following benefits:

Require less operating and storage space; No toxic chemical residence after degraded. Remove and prevent H<sub>2</sub>S and TVOC formation faster than any known chemical method. Excellent Reproducible Results; Easy to Control the Dosages and Potency Sustained up to 16-24 hours Contributes dissolved oxygen Prevent sewer and leach line constriction, it does this in two ways: 1) it oxidizes microbial slimes that block leach lines; and 2) it decomposes once permeated into the sewer line system, liberating oxygen, conversion from a liquid to a gas represents a volume expansion whereby the compacted soil is "lifted" and airspace restored to the soil structure.



Order Information:

Tel: +852-2171-4882

Fax: +852-2385-7457

Web: [www.abs-hk.net](http://www.abs-hk.net)

Email: [gkw@abs-hk.net](mailto:gkw@abs-hk.net)

# ABS Microbial Growth Enhancer

## Serving Hong Kong and the World Since 2001

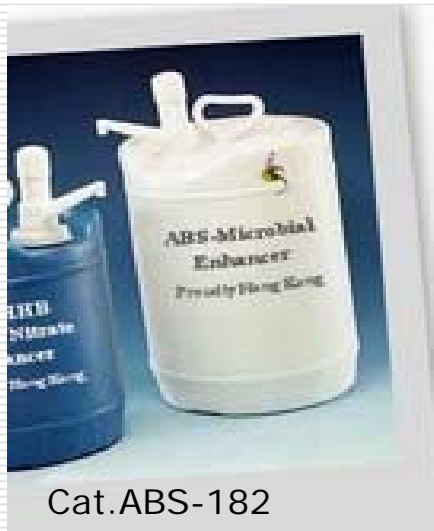

**ABS-Microbial Enhancer:** is a Biochemically/Biological remediation medium in conjunction with 29% Calcium Nitrate or stand alone to prevent the re-buildup of Toxic Gases in Sewer Line to protect Life, prevent Sewer Line Constriction, anti-corrosion, expand its lifespan and reduce the organic loading to save exponential cost in Sewer Line Cleanup and wastewater treatment costs, whilst providing the following benefits:

Decomposes once permeated into the sewer line system, liberating Biochemically generated oxygen, bacteria growth factors and essential co-enzymatic nutrient to increase the microbial productivities to prevent the re-buildup of Hydrogen Sulfide and slow down the slime growth rate. Balancing and Maintenance of the natural Sewer Conveyance Ecology.



Order Information:

Tel: +852-2171-4882

Fax: +852-2385-7457

Web: [www.abs-hk.net](http://www.abs-hk.net)

Email: [gkw@abs-hk.net](mailto:gkw@abs-hk.net)

# ABS Hydrogen Hydroponics and Agricultural Hydrogen Peroxide Enhancer

## Serving Hong Kong and the World Since 2001

---



Cat. ABS 181-HA

Order Information:

Tel: +852-2171-4882

Fax: +852-2385-7457

Web: [www.abs-hk.net](http://www.abs-hk.net)

Email: [gkw@abs-hk.net](mailto:gkw@abs-hk.net)

**ABS-oxygen alleviating medium** is a preparatory preparation; when blend with hydrogen peroxide 4 more atoms will be added to hydrogen peroxide. Chemically, hydrogen peroxide is disproportional unstable chemical compound. Thus, it will not survive unless some traces of ions are present to act as catalysts of the reduction of hydrogen peroxide to water. When ABS-oxygen alleviating medium is added to hydrogen peroxide, the solution will full of ions of right potential range for reduction, effectively releasing oxygen atoms in exceptionally slow rate to providing extra oxygen to the plant. Oxygen is the major component of the plant structure and rather is one of the elemental nutrients the plant feed on, it also perform many important function within the plant participation in all metabolic process. Adding abs-oxygen medium with hydrogen peroxide will grant extra oxygen to help with the following functions:

1. Root uptake
2. With transport mechanisms within plant structure
3. Stimulate protein production at a cellular level, enhancing photosynthesis.
4. Break down the carbohydrates created through photosynthesis
5. Applicable to All Strength of H<sub>2</sub>O<sub>2</sub>.

30%w/w H<sub>2</sub>O<sub>2</sub> with ABS Enhancer = dilute 0.1ml to 500ml water

20%w/w H<sub>2</sub>O<sub>2</sub> with ABS Enhancer = dilute 0.1ml to 500ml water

17.5%w/w H<sub>2</sub>O<sub>2</sub> with ABS Enhancer = dilute 0.1ml to 500ml water

ABS Hydrogen Peroxide Enhancer is highly miscible with 6% to 50% industrial or food grade hydrogen peroxide instantaneously and maintain the potency for up to 2 years if capped well after opened and stored away from the sunlight at room temperatures.

# ABS Hydroponics and Agricultural Microbial Growth Enhancer

Serving Hong Kong and the World Since 2001

---



Cat. ABS-182-HA

Order Information:

Tel: +852-2171-4882

Fax: +852-2385-7457

Web: [www.abs-hk.net](http://www.abs-hk.net)

Email: [gkw@abs-hk.net](mailto:gkw@abs-hk.net)

**The ABS Hydroponics Enhancer:** contain many of the growth factors and various other essential nutrients and oxygen energizer in a form readily available to stimulate desirable, naturally occurring Reactive Oxygen Species, while concurrently inhibiting the Undesirable anaerobic bacteria.

With supplementing the ABS microbial enhancer series of product to organic matter, the metabolic activity of the Reactive Oxygen Species will significantly increased, providing rapid and effective degradation of the undesirable organic masses.

**Active ingredients:**

Fish Oil Extracts

12 essential vitamins

8 essential micro-nutrients

Sodium Gluconate, Chitosan, Seaweed Extracts

Proprietary blended with vegetative saponin



## Product from Our Associate Manufacturers in Malaysia

Landfill Wood Waste, Forest Fire Mitigation., Wildfire Hazard Reduction  
Agricultural / Plantation Waste, Wood Waste from Construction and Demolition  
Works, Biomass waste generated from land clearing activities

---



### Environmental Benefits of Air Curtain Incinerators :

- ❑ 100% combustion with minimal escaped particulates.
- ❑ Virtual elimination of smoke
- ❑ Residual ash can be used as soil amendments
- ❑ Fast burning throughput between 5 to 12 metric tons/hour

# Product from Our Associate Manufacturers in Holland

Solid pre-selected household waste  
Solid mixed household waste  
Commercial, shop and office waste  
Green / biological ("bio") waste  
Bulky Waste i.e. Refrigerator, Tires, TV etc



# Product from Our Associate Manufacturers in Holland

## Integrated Hospital/Hazardous Waste Pyrolysis Gasification Incinerator with Self-generating Bio-Energy Unit

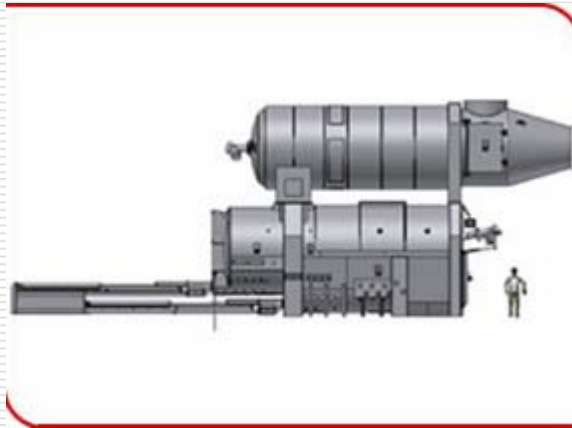

**Should the product you look for is non listed here, please send us an email; we are more than happy to source for you...There's NO Can't Do here.....**

---

**Environmental Equipments, Holland:** 1) Landfill, 2) Solid Waste Management; 3) Consultancy

**Minerals Worldwide:** 1) Coppers, 2) Aluminum, 3) Iron, 4) Tin, 5) Feed Grade Minerals

**Chemicals Worldwide:** 1) Water Treatment 2) Food Additives, 3) Wastewater Treatment, 4) Organic Acid

Energy of Tomorrow Spain and United Kingdom: Bio-fuel Production Technologies and Investments.

**Chemicals India:** 1) Herbal Pesticide; 2) Fungicide; 3) Non Contaminated Ocean Seaweeds Fertilizers

**Essential Oil/Essence Oil, India:** 1) Industrial; 2) Skin Care, 3) Medicinal, 4) Hydroponics

**Natural Insects Repellent Lotions, Hong Kong:** 1) Mosquito Repellent and Sanitizer; 2) Essence Oil, 3) Vitamin Based Hand Sanitizer

Order Information:

Tel: +852-2171-4882 Fax: +852-2385-7457

Web: [www.abs-hk.net](http://www.abs-hk.net) Email: [gkw@abs-hk.net](mailto:gkw@abs-hk.net)

---